

## Reddi-Crate®

Laminated  
paper packaging

### Reliable Performance

Superior strength offers protection throughout shipping and handling

### Cost-effective Solution

Excellent replacement for traditional flat products and wooden crates

### Application Versatility

Available with protective coatings for moisture resistance and corrosion protection

### Highly Sustainable

Manufactured with 100% recycled materials and is 100% recyclable

# Reddi-Crate

## Laminated paper packaging



Reddi-Crate laminated paperboard packaging helps prevent product damage that can occur during shipping and handling. With a smooth surface and interior that is non-abrasive to products, Reddi-Crate can be used inside or outside a carton for product unitization and edge protection or helps to provide additional beam strength.

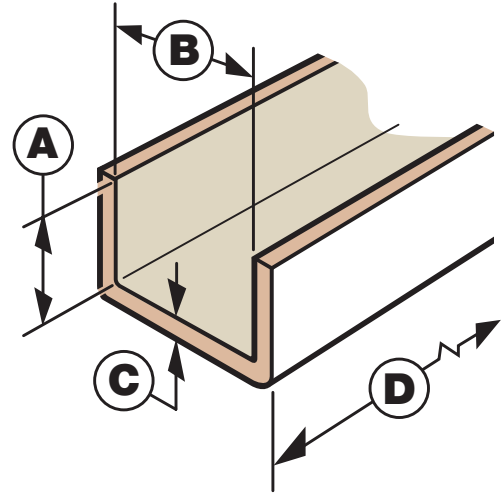
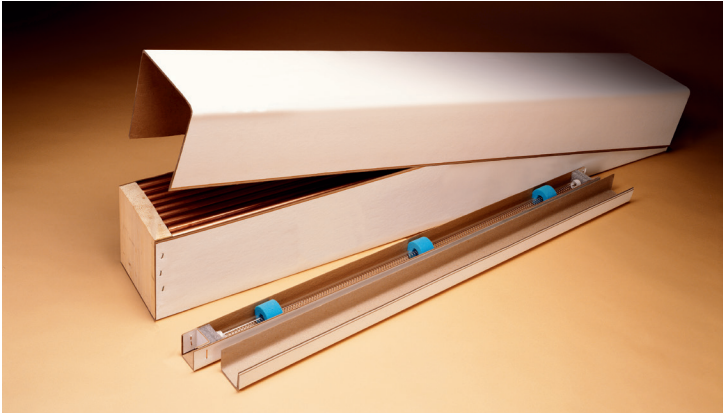

### Features and benefits

#### ■ Simplifies use

Reddi-Crate's preformed profiles and two end closures form a shipping container that provides superior strength and protection throughout the transportation cycle.

#### ■ Application flexibility

Reddi-Crate provides protection for a wide range of products. It can be treated with protective coatings to provide moisture resistance and corrosion protection for those products exposed to humidity, condensation and other environmental conditions.

#### ■ Product marketing

Reddi-Crate can be printed, allowing for branding, product identification and point-of-sale merchandising.

### Reddi-Crate Technical Specifications

<b>A   Leg Height</b>	Available from 25-203 mm (1-8 in)
<b>B   Base Width</b>	Available from 25-305 mm (1-12 in)
<b>C   Caliper</b>	Available from 1.5-13 mm (.060-.500 in)
<b>D   Length</b>	Available up to 16 m (53 ft)