



LITLED AVID
A **SIGNODE** BRAND

PRODUCTS
SERVICES
INTEGRATION
AUTOMATION



pack



bundle



unitize



warehouse



transport



LDX-RTB 4.0 Premier

Semi-automatic random case sealer

Maximizes Productivity

Performance operating speed of 155 feet per minute

Simplifies Maintenance

Easy access to motors, electrical components and belts for routine maintenance

Production Versatility

Patented technology enables processing of void-filled and over-stuffed cases with pneumatic tape cartridges

Robust Design

Case-hardened rollers & nonmechanical side rail actuation for long-term performance & durability



LDX-RTB 4.0 Premier

Semi-automatic random case sealer

The semiautomatic LDX-RTB random case sealer's high belt speed makes it possible to process boxes at speeds up to 155 feet per minute. The LDX-RTB integrates CaseLocker™ series tape cartridges for high-speed production environments.

Standard Machine Features

Performance

- Allen-Bradley Micro 820 PLC
- Ethernet connectivity
- Photo eye detects box back-up in the case sealer
- Easy programming

Versatility

- Operates from either side with movable controls

Durability

- Top drive assembly travels on hardened steel components
- Long lasting non-contact sensors activate height and width adjustments

Hardware

- Performance speed 155 FPM conveyor drive
- Dual locking caster wheels 4" (102 mm)
- Low-tape / No-tape / No-cut detection
- Roller bed extension (entry side)
- Standard CaseLocker™ 60 cartridge (lower)
- Pneumatic CaseLocker™ 61 cartridge (upper)

Enhanced Machine Features

Smart Guarding

Equipped with an interlocked hinge, these four guard panels automatically initiate the Maintenance Mode when opened by the operator.

Certified

Every LDX-RTB is Nationally Recognized Testing Laboratory (OSHA NRTL) certified for its electronic components.

Operator Controls

E-Stop, Start and Stop functions are separated for operator friendly control of machine. Controls can be mounted on either side of machine. Controls can be on both sides of machine with "Dual Operator Controls" option.

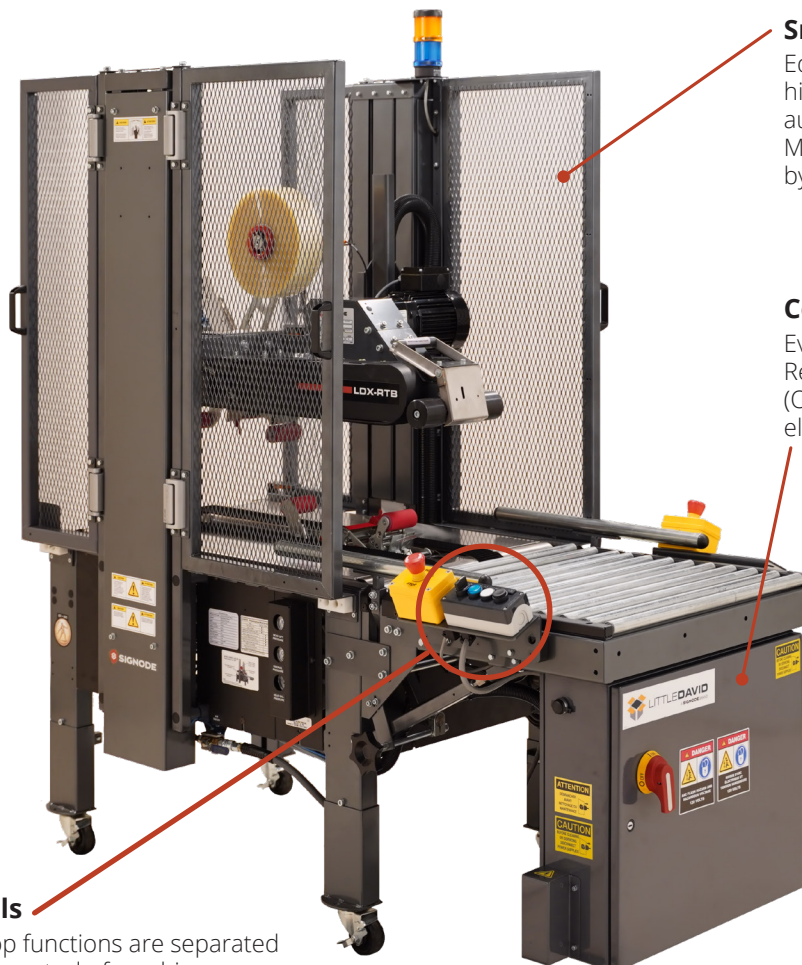

Intertek
Certifications

CSA C22.2#301:2016 Ed.1
Industrial Electrical Machinery

UL SUBJECT 2011:2021 Ed.6
Outline of Investigation
for Machinery

CaseLocker™ 60 Tape Cartridge

- Simplified threading path for loading tape.
- Patented locking knife guard system allows the blade to only be exposed when rollers are depressed.
- Easy to replace tape roll.
- Patented tool-less removal of cutter blade and wipe rollers
- No lubrication required.



CaseLocker™ 61 Tape Cartridge

- Patented pneumatic assist and secondary arm spring for high speed operation and ability to apply tape to underpacked cases.
- Patented locking knife guard system allows the blade to only be exposed when rollers are depressed.
- Easy to replace tape roll.
- Patented tool-less removal of cutter blade and wipe rollers.
- No lubrication required.



Dual E-Stop

Equipped with a secondary E-stop for operator convenience.

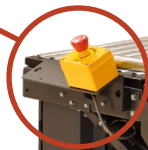

CaseLocker™ 61 Tape Cartridge

Belt Guards

Pinch point prevention when other Material Handling Equipment is placed flush against exit side of machine.

CaseLocker™ 60 Tape Cartridge

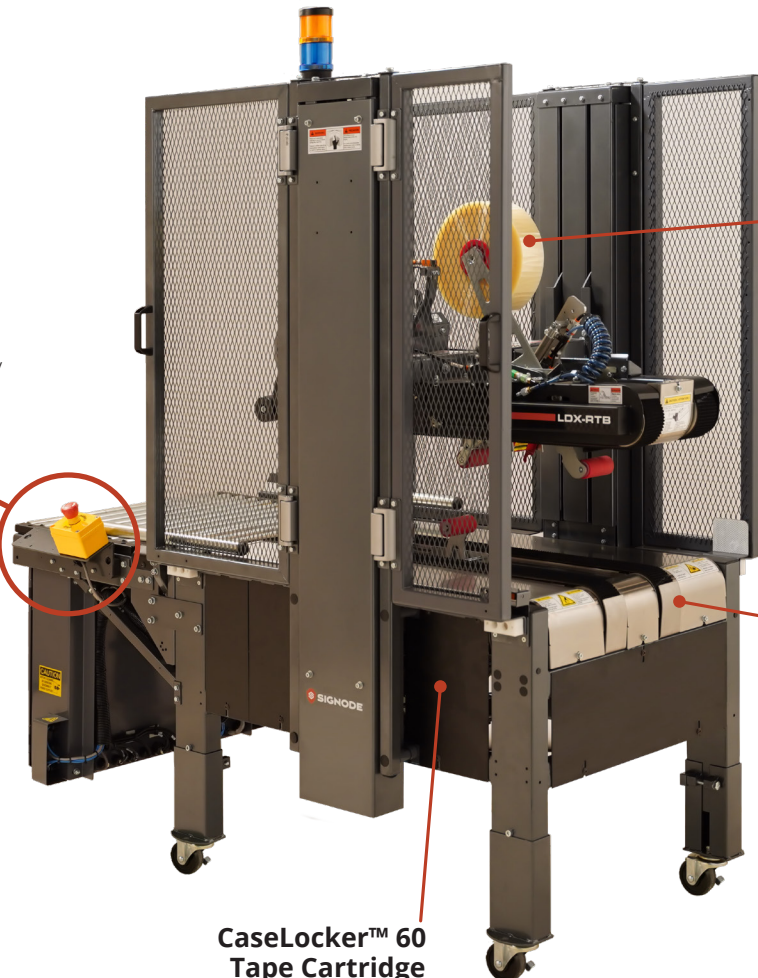

LDX-RTB 4.0 Premier

Semiautomatic random case sealer



Available Options

- 3-phase electrical package
- 115 FPM conveyor drive
- Dual Operator Controls
- Air dryer
- Exit conveyor backup detection
- Exit transfer table (roller bed)
- HMI
- Pass-through feature
- Spare parts kit
- Spare tape cartridges



Major Machine Dimensions

Machine Dimensions	Length (L): 54.2" (163 cm) Width (W): 36.6" (93 cm) Height (H): 71.88" (182.5 cm) **
Conveyor Height	Standard 26.50" - 31.75" (67.3 - 80.6 cm) Consult sales for other heights

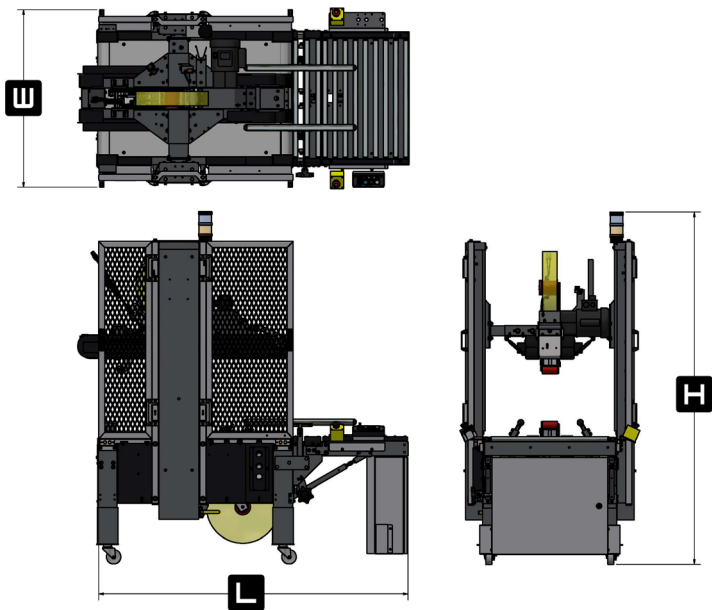

Technical Specifications

Power	115 volts, 60 cycle, single-phase
Air	9 SCFM @ 95 psi
Operating Speed	Standard 155'/minute (47.25 m/min) Optional 115'/minute (35.05 m/min)
Case Range	Length: 6" (152.4 mm) - infinite Width: 5.5" - 26" (139.7 mm - 660.4 mm) Height: 3.5" - 24" (88.9 mm - 609.6 mm) *
Weight	570 lbs. (258 kg.)
Limited Warranty	1-year; Tape cartridges, complete drive system, motor/ gear reducer 60-days; wear items and moving parts
Closure Material	Pressure sensitive tape

* Consult sales for cases with heights less than 3.5" (88.9 mm)
** Machine height at minimum conveyor height.