

ITW Angleboard

Cornerboard™



The perfect edge to protect your product line

- Stronger than Laminated Paper
- Water-Resistant
- Printable Outer Wrap
- Ideal for Outdoor Conditions

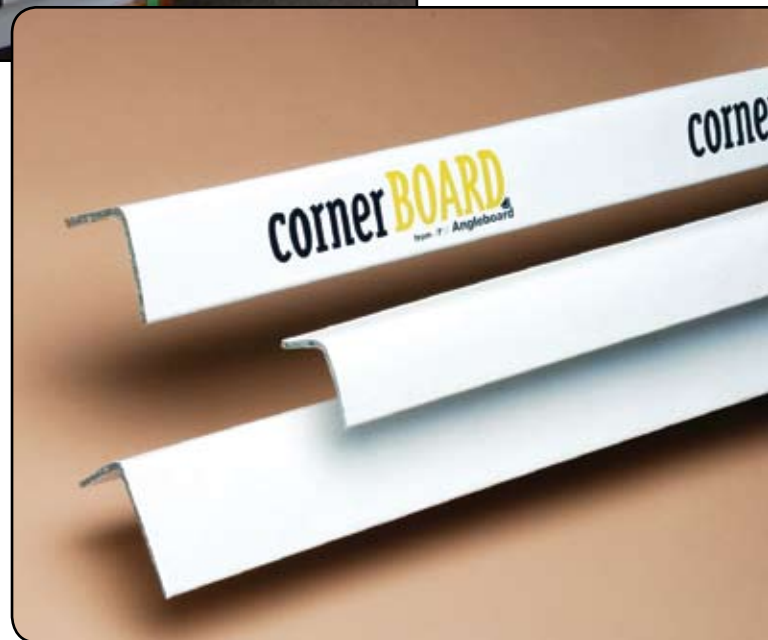

100% Recyclable

ITW Angleboard products are made from 100% recycled materials and are 100% recyclable.

ITW Angleboard

We've got all the angles covered.

ITW Angleboard

Cornerboard



RECLAIM • RECYCLE • REUSE

Cornerboard™ is a high-strength, moisture-resistant corner post made of recycled paper and plastic with a paper outer wrap. The plastic content enables Cornerboard exposure to moisture for long periods of time without deteriorating, making it ideal for products that are shipped on flat bed trucks, stored outdoors, or exposed to high humidity.

Cornerboard:

- Delivers greater strength than conventional paper products
- Offers more pieces per pallet which reduces freight and storage costs
- Works well with refrigerated/frozen food where condensation is a problem
- Easily accepts nails, staples and screws
- Is recyclable and reclaimable

One and two-color printing is also available for branding, product identification and instructional purposes.

ITW Angleboard

595 Telser Road • Suite 100 • Lake Zurich, Illinois 60047

Phone: 1-800-252-4777 • www.angleboard.com

100% Recyclable

ITW Angleboard products are made from 100% recycled materials and are 100% recyclable.

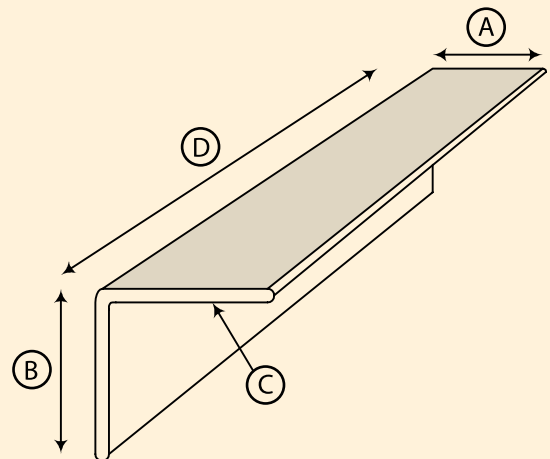

Specifications

Cornerboard sizes are based on the following dimensions*:

- A Leg Length One – Available from 1.5 – 3 inches (38.1 mm – 76.2 mm)**
- B Leg Length Two – Available from 1.5 – 3 inches (38.1 mm – 76.2 mm)**
- C Caliper – Available from .100 – .250 inches (2.5 mm – 6 mm)**
- D Length – Available from 6 inches – 240 inches (152.4 mm – 6,096 mm)**

*Together, the Cornerboard leg lengths cannot be more than 6 inches (152.4 mm).

ITW Angleboard We've got all the angles covered.

©2009 ITW Angleboard AM-0015 02/09 NP