

New!

SIGNODE

HB-4310™

Side seal plastic strapping machine

**Jam-resistant
technology**

**52 straps
per minute**

**Automatic
cut-off and
refeed option**

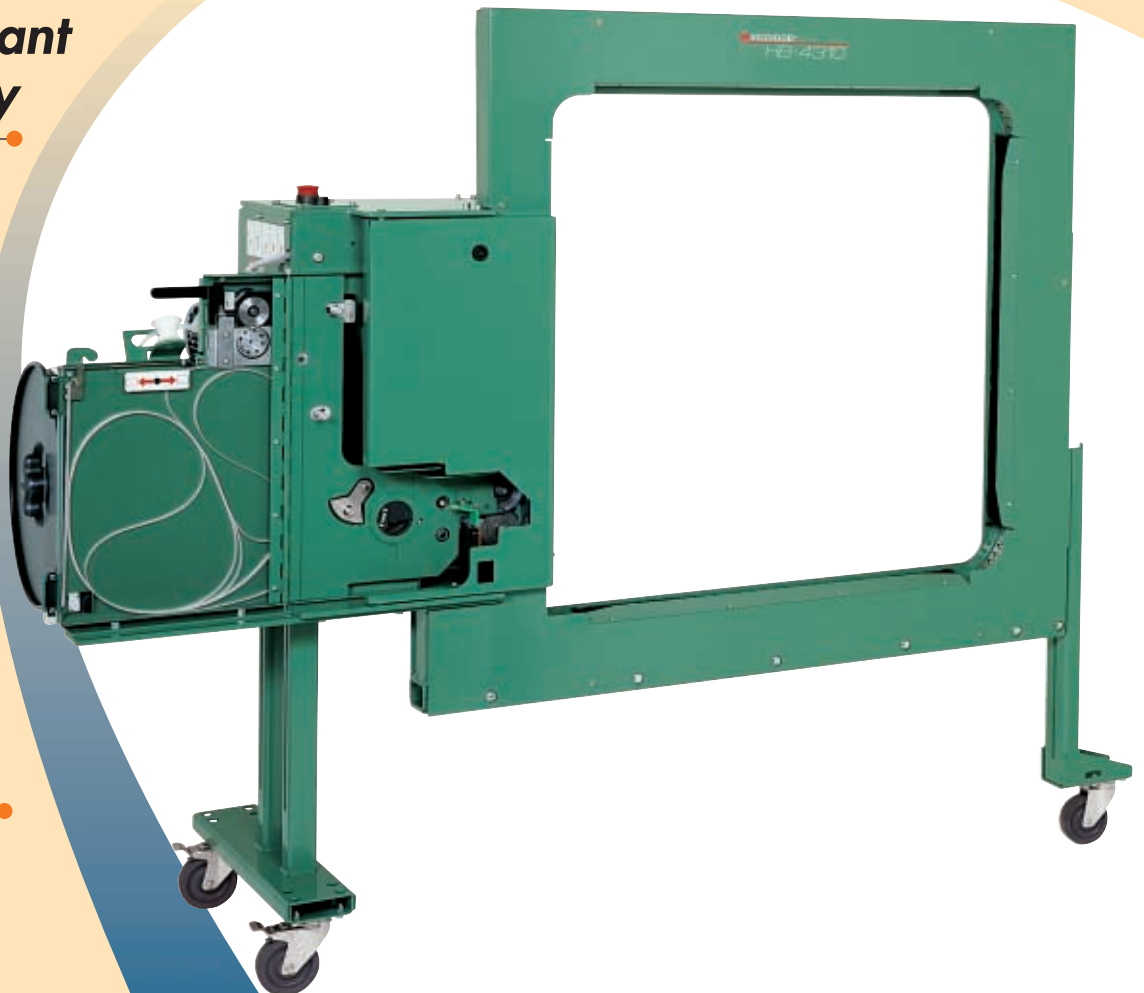

SIGNODE®

A new generation of strapping systems from Signode

Signode Packaging Systems introduces the HB-4310™ side seal plastic strapping machine with the highest available speed, most reliable performance and lowest maintenance cost of any general-duty, side seal strapping machine on the market today. Whether your operation requires a semiautomatic or fully automatic strapping system, the HB-4310 increases production speed, reduces operator involvement and simplifies service functions to save you time and money.

Jam-resistant technology

The HB-4310 strapping machine is designed to deliver the most jam-resistant technology available.

Unequaled speed

Cycling up to 52 straps per minute, the HB-4310 is the fastest strapping machines in its class.

Automatic loading

Two simple steps:

1. Lift the lever, and insert the strap end into the slot.
2. Turn the power on, and push the cycle button. The machine threads itself and is ready to go.



Automatic cut-off and refeed option

Unlike other automatic strapping machines that require an operator to clear strap jams, the Signode HB-4310 (using Signode's patented automatic cut-off and refeed option) automatically ejects misfed strap, rethreads itself and continues strapping without operator intervention. Equipped with this option, the automatic model becomes a truly operatorless machine.



Easy access to strapping head

Machine and strapping guides are easily opened, providing complete access to the strapping head in less than 20-seconds without using any tools.



Simple operator controls

Simple operator controls make it easy to perform all machine functions without specialized operator training.

Lubrication-free operation

The HB-4310's self-lubricating design provides excellent durability and maintenance-free operation.

High tension

The patented tension winder mechanism ensures consistent, high tension (up to 250 lbs.) regardless of package size or compressibility.

The Signode System

Since 1913, the name Signode has meant reliable, durable, high quality protective packaging systems that improve your package, protect your product and increase your profits.

When you buy from Signode, you get top quality products made in the U.S.A., plus the maintenance, technical and engineering resources needed to meet your ongoing packaging needs. Toll-free technical assistance and emergency shipment of stocked parts are available 24 hours a day, 7 days a week by dialing **1-800-527-1499**.



Your Signode sales representative can visit your plant, test alternative solutions, document cost versus savings and recommend appropriate products.

You can get 24-hour shipment of spare parts and a consistent supply of Contrax® strapping from our nationwide network of manufacturing, distribution, and customer service centers conveniently located to serve you.

HB-4310™

Corrosion resistant stainless steel model (shown below).
Available in 24" x 24" chute size only.

Built-in cycle counter for preventive maintenance programs

Hinged door provides quick access to the strapping head

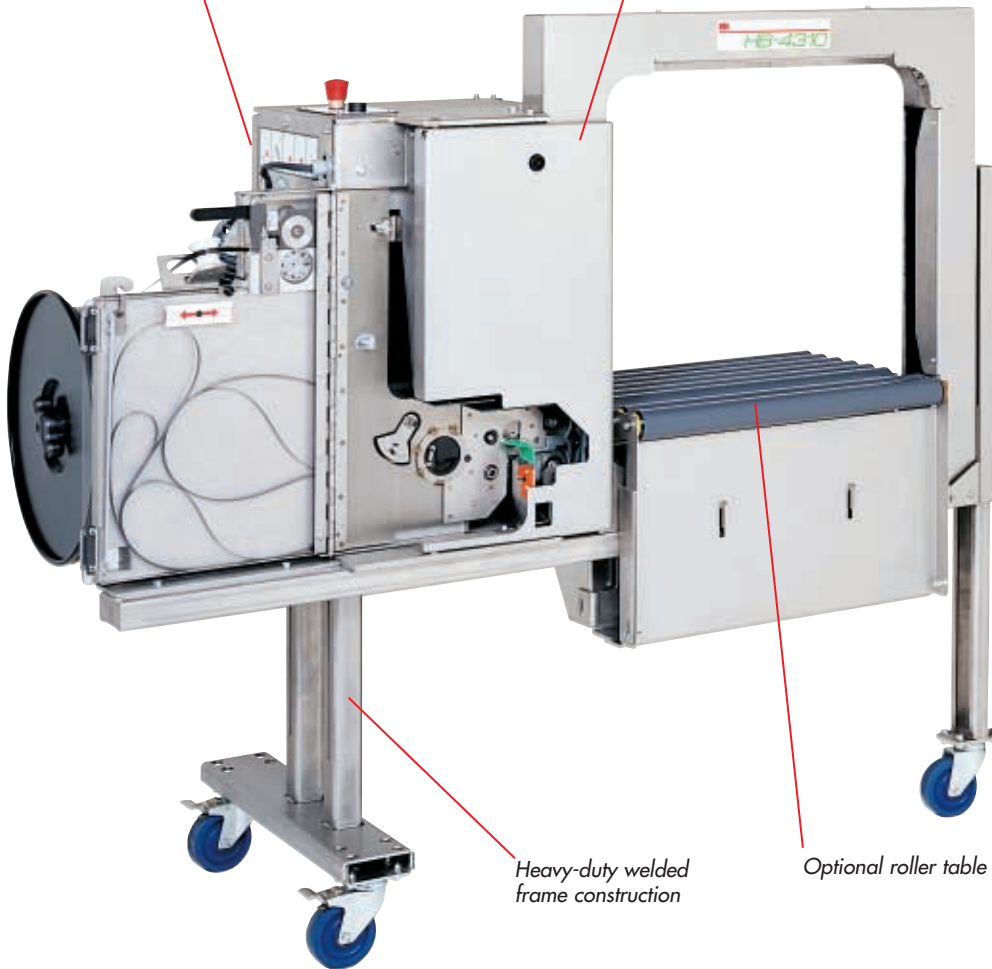

Heavy-duty welded frame construction

Optional roller table

Easy access hinged doors



Accumulator box



Strap path

Options

■ Corrosion resistant model

Ideal for food processing and packaging applications where condensation is a problem.
(Not for wash down applications.)

■ Automatic cut-off and refeed

■ Operatorless interlock kit

Synchronizes the HB-4310 with your present handling system.

■ Roller table

Aligns the HB-4310 with your conveyors. Available on 24" x 24" model only.



■ Auxiliary push button station

For manual cycling and main power.

■ Foot cycle switch

Activates strap cycling for flexible operation.



Contrax® plastic strapping



Enhance the quality and performance of your HB-4310 side seal strapping machine with Signode Contrax polypropylene strapping.

- Consistent width and gauge control
- Smooth, uniform surface
- Resists splitting
- Recovers when elongated
- Recyclable (ask about Signode's recycling program)

HB-4310 Side Seal Specifications

Production rate

Up to 52 straps per minute in a 36" x 36" chute with a 34" x 34" package. Actual production will vary depending on package size, chute size and operator dexterity.

Chute size

See chart and illustration on right.

Maximum package weight

25 lbs. per roller on the 24" x 24" model only.

Strapping

9mm or 10.5mm polypropylene strapping.

Strap tension

Adjustable up to 250 lbs.

Conveyor height

24" x 24" model: Adjustable from 340 mm to 695 mm (13-3/8" to 27-3/8"). All other models: Adjustable from 195 mm to 635 mm (7-11/16" to 25").

Electrical requirements

Standard: 120 volt, 60Hz

Optional: 208 volt, 3 phase, 60Hz, 6.4 amps
 230 volt, 3 phase, 60Hz, 5.9 amps
 460 volt, 3 phase, 60Hz, 3.1 amps
 575 volt, 3 phase, 60Hz, 2.6 amps

Shipping weight 700-950 lbs.

Chute inner dimensions

	Small chute		Medium chute		Large chutes			
	mm	inches	mm	inches	mm	inches	mm	inches
A	610	24	914	36	1219	48	1524	60
B	610	24	914	36	1524	60	1524	60

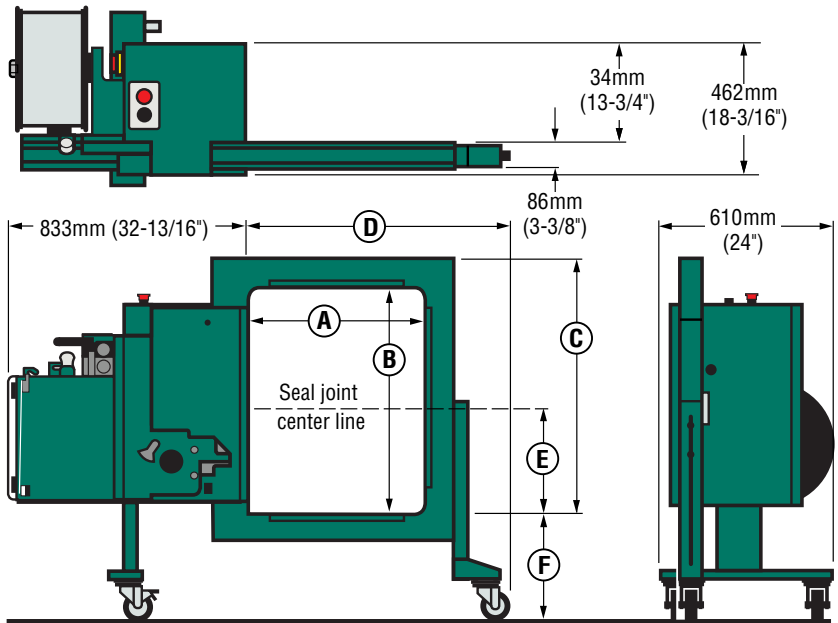

C. Chute height

Small chute: 746 mm (29-3/8")
 Medium chute: 1094 mm (43-1/16")
 Large chute: 1688 mm (66-7/16")

D. Chute length

Small chute: 848 mm (33-3/8")
 Medium chute: 1299 mm (51-1/8")
 Large chute: 1607 mm or 1894 mm (63-1/4" or 74-9/16")

E. Seal height

24" x 24" model: 229 mm (9") standard; adjustable 51mm to 152mm (2" to 6") with optional roller table.
 All other models: 375 mm (14-3/4")

F. Chute opening (conveyor) height

24" x 24" model: Adjustable 340 mm to 695 mm (13-3/8" to 27-3/8")
 All other models: Adjustable from 195 mm to 635 mm (7-11/16" to 25")

SIGNODE®

3610 West Lake Avenue
 Glenview, Illinois 60025
 1-800-323-2464