

Rotary Arm Series Stretch Wrappers

COBRA[®]

1525CN Automatic

High Performance Octo-Thread carriage



Simplified film
threading with
improved operator
ergonomics



Cobra 1525CN with standard infeed, process and exit conveyor. Shown with Deluxe Fencing. Conveyor-Ready Cobra 1525CR also available.

- Wraps up to 40 loads per hour
- Heavy duty construction
- Pre-stretches film up to 300%
- Installs over existing conveyor or can be provided with conveyor
- Positive, non-slip V-belt rotation drive
- Allen-Bradley PLC with operator interface
- Octo-Thread carriage allows easy film threading
- Strain gauge film delivery control
- 3-1/2" dia. conveyor rollers on 3-3/4" centers (1500CN model)

 **SIGNODE[®]**

Cobra 1525CN

Automatic Rotary Arm Stretch Wrapper

Specifications

Standard configuration listed below. Please contact your sales representative for other available configurations.

Performance

Loads per hour	Up to 40
Rotation speed	12 rpm (optional to 18 rpm)
Maximum load size	50" x 50" x 80" H (70" dia.)
Minimum load size	36" x 36" x 28" H (film clamp justified)
Maximum load weight	1525CN: 4,800 pounds 1525CR: dependent on conveyor

Film Delivery System

Film capacity	20" roll width x 10" dia.
Pre-stretch type	Strain gauge
Pre-stretch level	250% (optional 100% to 300%)
Force control	Variable
Film threading	Octo-Thread design; W film threading pattern
Cut and seal	Controlled impulse cutter and heat sealer

Controls

Controller	Allen-Bradley PLC
Operator interface	Touch screen
Load height sensor	Photo eye
Wrap settings	Re-wrap function; overwrap and overlap adjustments
Wrap counters	Independent top and bottom
Cycle counters	Total cycle counter and resettable counter
Emergency stop	Mushroom head
Electrical disconnect	Lockable
Electrical enclosure	CSA approved

Power Requirements

Voltage	480 VAC, 30 amp, 3 phase, 60 Hz
Pneumatic	80 psi, 3 CFM (clean, dry air)

Rotary Arm

Drive system	Dual V-belt drive
Bearing type	Dual pillow block bearings

Structure

Machine weight	1525CN: 7,150 pounds 1525CR: 2,000 pounds
Construction	Heavy duty, welded
Color	Dark bronze
Rotating arm color	Yellow

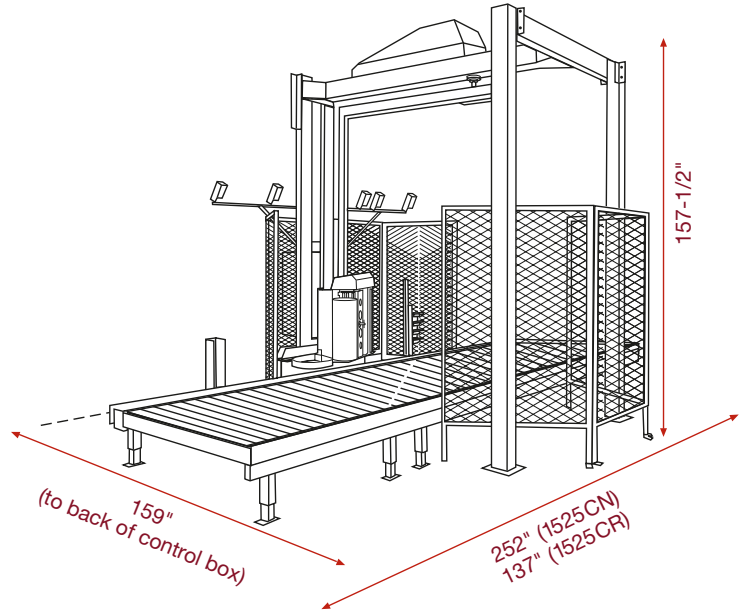

SIGNODE®

Signode Packaging Systems
3610 West Lake Avenue
Glenview, Illinois 60026
1-800-323-2464
www.signode.com